



**rvtech**

**TECHNOLOGIE FÜR REISEMOBILE**

## **CENTRAL LOCKING**

**FOR STORAGE COMPARTMENT DOORS IN  
MOTORHOMES**



# **INSTALLATION INSTRUCTIONS**

**DOWNLOAD  
IN COLOR  
[rv-tech.de](http://rv-tech.de)**



## CONTENTS

<b>1 IMPORTANT NOTES</b>	p. 3
<b>2 SCOPE OF DELIVERY</b>	Pp. 4-6
<b>2.1 STS / Happich VARIANT</b>	p. 4
<b>2.2 VARIANT Carthago / FAP</b>	p. 5
<b>2.3 VARIANT Hymer Leichtmetallbau</b>	p. 6
<b>3 INSTALLING THE LOCK</b>	pp. 7-13
<b>3.1 VARIANT STS / Happich</b>	Pp. 7-8
<b>3.2 VARIANT Carthago / FAP</b>	pp. 9-12
<b>3.3 VARIANT Hymer Leichtmetallbau</b>	p. 13
<b>4 INSTALLING THE CONTROL UNIT</b>	pp. 14-20
<b>5 WIRING THE LOCKS</b>	Pp. 21-23
<b>6 CHECKING THE STS/HAPPICH LOCKING DEVICES</b>	p. 24
<b>IMPRINT</b>	p. 26



## 1 IMPORTANT NOTES

### Please observe the following safety instructions

We generally recommend having the central locking system installed by a specialist.

We accept no liability for improper installation or fitting.

The product—especially its packaging—may contain small parts that could be swallowed. **Keep away from children!**

Technical details are subject to change without notice and may differ from the illustrations in these installation instructions.

### Risk of injury

Each individual step in these installation instructions must be followed precisely. **Be sure to disconnect the vehicle and body batteries during wiring work!**

### Gas compartments

**Caution:** According to German standard DIN EN 1949 (*"Specifications for the installation of liquid gas systems in habitable recreational vehicles and for residential purposes in other vehicles"*), no electrical installations may be carried out in the gas compartment.

This means that **for safety reasons, you must not attach any locks to the storage compartment flap of your gas compartment!**

### Requirements for installation

The locks/actuators supplied are **only suitable for installation in recessed handle locks from Happich, FAP, Hymer Leichtmetallbau, and STS.**

Other locks cannot be retrofitted with them.

### Validity

The installation instructions are valid for: **Central locking for storage compartment flaps of the RV tech starter set, including extensions**

### Technical data

Control unit:	0.3 kg
Locking	0.1 kg
Maximum number of locks that can be connected:	8 / 16 with V cables
Power supply:	10.5 - 14 volts, depending on the number of connected actuators
Max. current consumption:	3 A (per lock)
Switch-on duration of the locks:	50 ms after activation



## 2 SCOPE OF DELIVERY

### 2.1 VARIANT STS / Happich

Your starter set includes:



**1 CENTRAL CONTROL UNIT**  
to which up to 8 locks can be connected



**4 ACTUATORS/LOCKING DEVICES**  
for your recessed handle lock from STS / Happich



**4 DETENT LEVERS**



**4 RETENTION CLAMPS**



**2 x 4 METER CONNECTION CABLE**  
**2 x 6 METER CONNECTION CABLES**  
for the locks



**1 CONNECTION CABLE**  
for the control unit incl. 15 amp fuse



**1 SWITCH CABLE**  
for your switch in the interior

## 2 SCOPE OF DELIVERY

### 2.2 VARIANT Carthago / FAP

Your starter set includes:



**1 CENTRAL CONTROL UNIT**  
to which up to 8 locks can be connected



**4 LOCKS INCLUDING LOCKING MECH.**  
for Carthago / FAP



**4 INNER COVERS**  
for Carthago / FAP



**1 REMOVAL KEY**



**2 x 4 METER CONNECTION CABLES**  
**2 x 6 METER CONNECTION CABLES**  
for the locks



**1 CONNECTION CABLE**  
for the control unit  
including 15 amp fuse

**1 SWITCH CABLE**  
for your switch in  
the interior



**1 TEMPLATE**



## 2 SCOPE OF DELIVERY

### 2.3 VARIANT Hymer light alloy construction

Your starter set includes:



**1 CENTRAL CONTROL UNIT**  
to which up to 8 locks can be connected



**4 ACTUATORS/LOCKING DEVICES**  
for your locks from *Hymer Leichtmetallbau*



**4 SPACER BUSHINGS**



**2 x 4 METER CONNECTION CABLE**  
**2 x 6 METER CONNECTION CABLES**  
for the locks



**1 CONNECTION CABLE**  
for the control unit  
including 15 amp fuse



**1 SWITCH CABLE**  
for your switch in the interior

### 3 INSTALL LOCK

#### 3.1 STS/HAPPICH VARIANT

##### 1. Removing the recessed handle lock (manufacturer: *Happich* or *STS*) from the vehicle

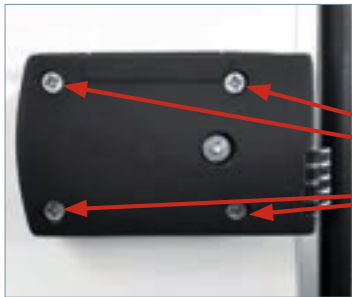

Completely remove the 4 screws and remove both sides of the lock from the flap (door)

##### 2. Remove the small wire spring on the inside of the lock and discard it



Spring

##### 3. Check that the lock moves smoothly

(If necessary, loosen the screw on the back of the lock case slightly and secure it with screw lock)



Screw

##### 4. In the part of the recessed handle lock that is on the inside of the motorhome, insert the black **deflection lever** over the pin.

Due to manufacturing tolerances on the recessed handle lock, the hole in the plastic lever may need to be drilled out.

*TIP: Try one of the other deflection levers first, as it may fit better.*





**5. Insert the circuit board with actuator into the lock case**

Make sure that the ball head of the actuator rests in the spherical cutout of the deflection lever.



**6. Finally, secure the circuit board with the retaining clip to prevent it from slipping.**

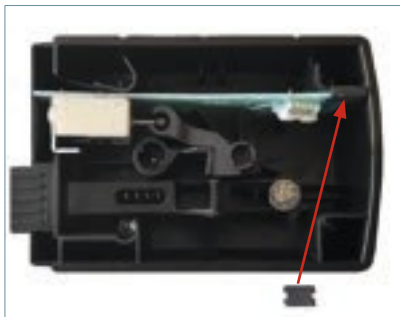

**7. After plugging the connection cable into the circuit board with the actuator, the lock can be reinstalled in the vehicle using the 4 screws (see point 1).**

*TIP: If the inside of your flaps are not lined with felt or carpet, it may be helpful to cut a small slot in the recessed handle lock so that the cable can be routed to the outside without pressure marks.*



### 3 INSTALL LOCK 3.2 CARTHAGO/FAP VARIANT

1. Remove all four screws from the inside lock on the inside of your storage compartment flap. Please ensure that the outer part of the lock remains in the cutout of your storage compartment flap.



Remove the 4 screws completely and remove only the inside of the lock from the flap (door).

2. After removing the inner lock and the frame underneath, please mark the side of the outer lock where the lock cylinder is located. This is where the cutout for the electric lock will be made later (see point 9). Depending on the vehicle manufacturer, the lock cylinder may be located at the edge of the flap or at the center of the flap. Proceed with extreme caution here to ensure that you make the cutout on the correct side of the inside of the flap.

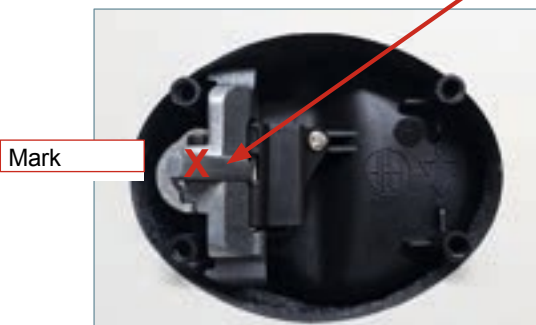

Mark

3. Pull out the outer part of the lock so that you can remove your lock cylinder.
4. Insert your key into the lock cylinder and turn it clockwise approx. 45° so that you can then pull it out in this position.



5. Insert the supplied **removal key** into your lock and pull the lock cylinder out of the outer lock by slightly tilting the removal key.



6. On the side of the lock cylinder where you see the large tab at the bottom, press the second tab in with your fingernail and pull the **removal key** out of the lock.



7. Reinsert the original key into the lock cylinder. Then insert the lock cylinder into the new **external lock** supplied, turn it slightly clockwise by approx. 45 degrees, and then push the lock cylinder completely into the external lock. You can now remove the key. The conversion of the external lock is now complete.



8. Use small scissors to cut out the oval from the **template** provided.

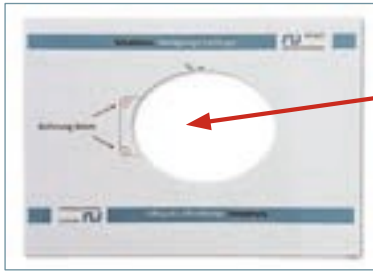

9. Attach the **template** to the inside of your flap.



The cutout for the two holes marked on the template should be on the side where you previously made your mark. (see point 2)

10. Transfer the centers of the two holes to the inside of your storage compartment flap.

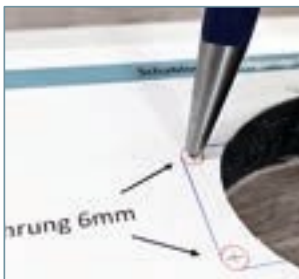

*TIP: Use a center punch or similar tool to make a small indentation in the sheet metal through the template, which you can then mark more precisely with a pen.*

11. Drill a hole through the sheet metal at the two marked points using a 6 mm drill bit.



*TIP: Proceed with caution so that you do not damage the outer panel!*

12. Trace the blue lines of the template onto the inside of your storage compartment flap using a ruler.



13. Cut through the sheet metal along the blue lines using an oscillating tool (e.g., FEIN MultiMaster) or a small jigsaw.

*TIP: Proceed with caution so that you do not damage the outer panel!*

Then carefully remove the insulation material behind it with a cutter until you reach the outer sheet metal.



14. Insert the new external lock (see point 7) into the storage compartment flap.



15. Place the supplied **inner cover** on the inside of the storage compartment flap over the lock.

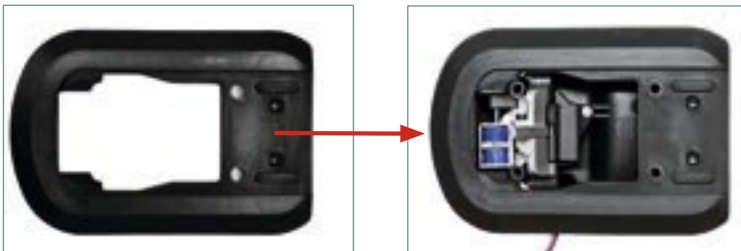

16. Finally, screw your existing inner lock onto the outer lock using the 4 screws. Please only tighten by hand.



Make sure that the **handle on the outer lock** does not protrude.



Also make sure that the **bolt on the inner lock** (see circle) must be pushed completely into the lock.

### 3 INSTALLING THE LOCK

#### 3.3 VARIANT Hymer lightweight metal construction

1. Remove all four screws from the inner lock on the inside of your storage compartment flap.

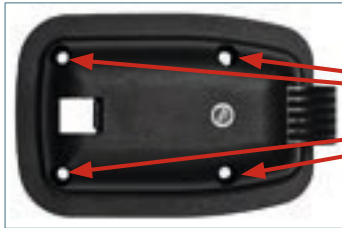

Remove the 4 screws completely and remove only the inside of the lock from the flap (door).

2. Place the **spacer bushing** in the inner lock.



3. Press the actuator **lock** into the inner lock. Make sure that the small **pin on the lock** threads into the guide of the inner lock.



4. After plugging in the connection cable, the lock can be reinstalled in the vehicle using the 4 screws (see point 1).

When connecting the cable, please ensure that the plug is completely inserted into the inner lock.

*TIP: If the inside of your flaps are not lined with felt or carpet, it may be helpful to cut a small slit in the recessed handle lock so that the cable can be routed to the outside without pressure marks.*



Add a slit for the cable if necessary  
Connection cable



## 4 INSTALL CONTROL UNIT

### 1. Attach the control unit to a suitable location in the motorhome using the 4 holes

*TIP: Position the control unit as close as possible to your body battery to minimize voltage drop during actuator operation.*

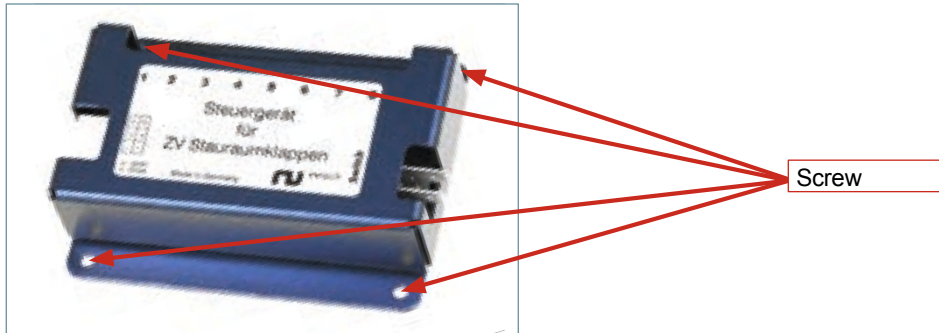

### 2. Connect the control unit to the 12-volt electrical system

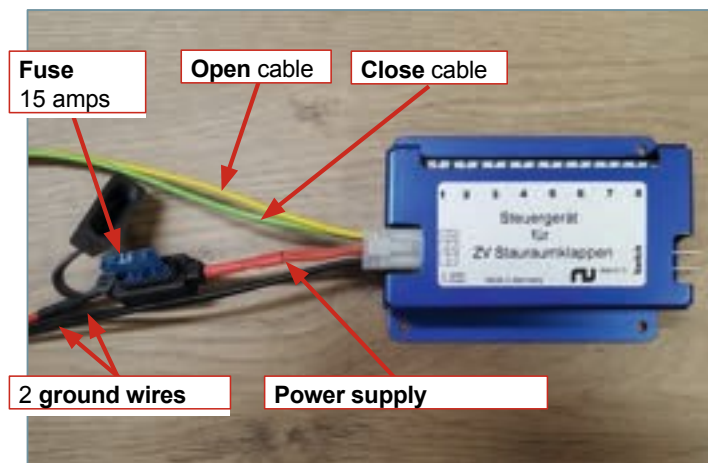

**Be sure to disconnect the battery before connecting the two power supply cables!**

First, shorten the two black ground cables as much as possible and connect both cables directly to the negative terminal of your battery or another suitable ground cable.

Now shorten the red power supply cable as much as possible and connect it to the positive terminal of your body battery or another suitable power supply cable.

**If in doubt, consult a specialist or have this work carried out by a specialist!**

Check the polarity of the cable with a measuring device (multimeter) before connecting it.

#### *Why it makes sense to shorten the connection cables*

*Each actuator (lock) requires 3 amps of current. The total current of all actuators therefore flows through a common connection cable. The shorter this cable is, the longer all actuators will continue to function even when the body battery is very low.*





**3. Connecting the control unit to the remote control of a FIAT Ducato base vehicle** (if your base vehicle is not a FIAT Ducato, please skip to **point 5**, "Vehicles without remote control of the base vehicle," p. 17).

**The control unit offers various connection options for opening or closing your storage compartment flaps.**

- a *If you only want to open or close your flaps using a switch inside your motorhome, please skip to **point 7**: "Connecting switches/buttons to the control unit," p. 19.*
- b *If you also want to connect all flaps to the central locking system of the base vehicle, you have the following two options:*

**- Connecting only the close cable (green cable):**

The storage compartment flaps are opened and closed using the switch in the interior (see 4., "Smart Open," p. 16) **and closed** using the **remote control**. (Not every motorhome owner likes unlocked storage compartment flaps at the rear of their vehicle). The remote control has higher priority than the switch.

**- Connection of the open cable (yellow cable) and the close cable (green cable):**

The storage compartment flaps are opened and **closed** using the switch in the interior (see 4., "Smart Open," p. 16) **and** using the **remote control**. The remote control has higher priority than the switch.

*Most living area doors can now be operated using the remote control of the base vehicle. This means that the storage compartment flaps can easily be integrated into this radio network.*

The living area door receives a 12-volt pulse on two different lines for opening and closing, which can be tapped for this purpose. Find these two lines near the living area door and connect one or both cables to the lines, depending on the desired variant.

**Example Carthago:**

If your living area door is already connected to the central locking system of the base vehicle, simply remove the black plastic step inside the vehicle. Behind it, you will find, among other things, the two connecting cables for the central locking system of the base vehicle to the living area door. There you can now connect the green *close cable* or the green *close cable* and the yellow *open cable* as described above:

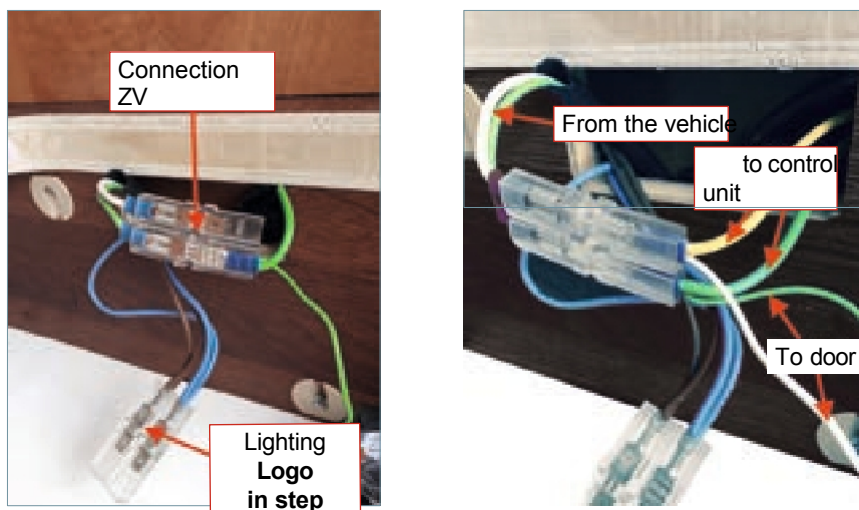



If your living space door is equipped with contact pins instead of an electrical cable between the door and door frame, you can remove the contact surfaces in the door frame and connect the cables there.

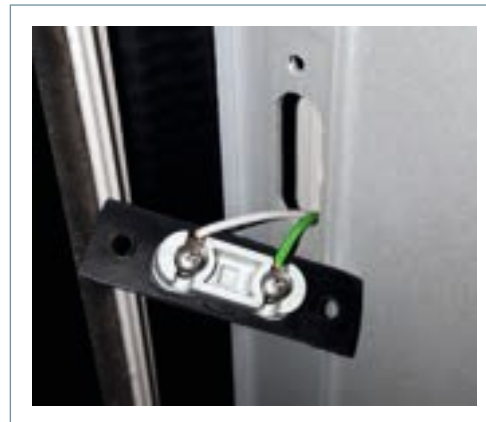
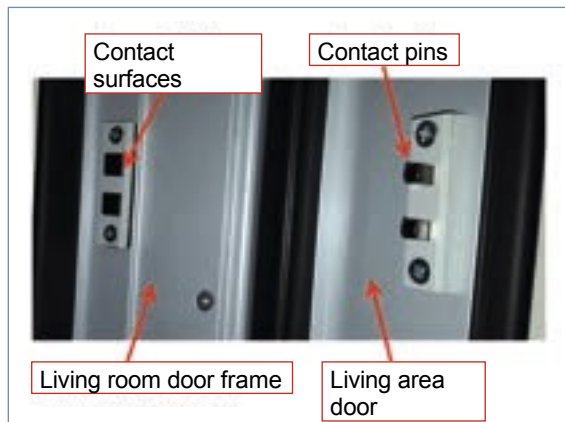

If your living area door is not connected to the FIAT Ducato's central locking system, you can also connect the *open cable* (yellow) and the *close cable* (green) directly to the Ducato's central connector. You will find it behind the passenger seat under a cover that is easy to remove.

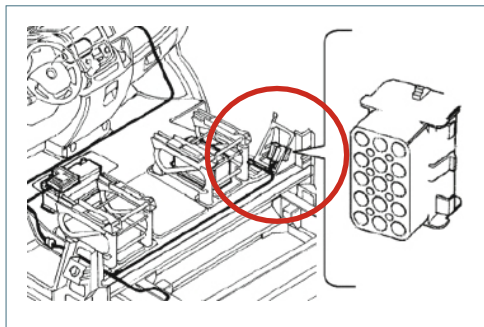

The **gray cable** in the large connector provides the impulse to open the storage compartment flaps and can be connected to the **yellow Open cable** as shown in the picture.

Please connect the **red cable** next to it to the **green close cable** of the control unit.

#### 4. Information about the *Smart Open*\* software version

Many motorhome owners don't like to see the storage compartment doors of their vehicle unlocked while the living area door is open. Because even if you are right next to your motorhome at the parking space or campsite, you can't keep an eye on everything...

**With *Smart Open*, you decide when your living area doors and storage compartment doors are open:**

Pressing the **open button** on your FIAT Ducato's remote control once will only open your living area door.

Press the **open button** a second time a second later to also open your storage compartment flaps.

To close all doors and storage compartment flaps, simply press the **close button** once.

Regardless of this, you can open or close all your doors and storage compartment flaps at any time using a **switch in the interior**.

Of course, you can also use your **conventional keys**.

**NOTE:**

*The pause between pressing the two opening options (1: doors / 2: flaps) must be slightly longer than 1 second. This is due to the system, as the FIAT's transmission pulse lasts just as long.*

*The second pulse must be sent within 4 seconds. Otherwise, the storage compartment flaps will remain locked.*



\* If you would like to open all flaps with a single button press as usual, please order our *Universal Starter Set* on our homepage at: [www.rv-tech.de/shop](http://www.rv-tech.de/shop)

The variants differ only in terms of their control unit software.



## 5. Vehicles without remote control of the base vehicle

*(For example: Concorde, Morelo, Niesmann+Bischoff, PhoeniX, and others...)*

**The control unit offers various connection options for opening or closing your storage compartment flaps.**

- a *If you want to open or close your flaps **using a switch inside** your motorhome, please go directly to **point 7**: "Connecting switches/buttons to the control unit," p. 19.*
- b *If you want to open your flaps **using a button inside** your motorhome and have them close automatically after 60 seconds, please select the **Auto Lock** option (see following page).*

*If you would also like to operate your storage compartment flaps using a remote control, we offer a **handheld transmitter set** on our website at: [www.rv-tech.de/shop](http://www.rv-tech.de/shop)*



## 6. Information about the *Auto Lock* software version \*

Many motorhome owners don't like to see the storage compartment doors of their vehicle unlocked while the living area door is open. Because even if you are right next to your motorhome at the parking space or campsite, you can't keep an eye on everything...

**With *Auto Lock*, your storage compartment doors lock automatically after 60 seconds. You don't have to worry about a thing.**

Pressing the button inside your motorhome opens your storage compartment doors. After 60 seconds, the locks are automatically locked.

If a storage compartment door is still open during this time, the lock will still be locked. Once the door is closed, everything is secure.

To reopen the storage compartment doors, simply press the button in the interior again.

Regardless of this, you can also open or close your storage compartment doors using our *handheld transmitter set* (available on our website at: [www.rv-tech.de/shop](http://www.rv-tech.de/shop)). Of course, you can also use your conventional keys to do this mechanically.

### NOTE:

*You can also install this option in Ducato motorhomes. However, there is a risk here that if you accidentally leave your remote key in one of your storage compartments and then cannot open your vehicle if the doors are locked.*



\* If you would like to open all hatches with a single push of a button as usual, please order our *Universal Starter Set* on our homepage at: [www.rv-tech.de/shop](http://www.rv-tech.de/shop)  
 The variants differ only in terms of their control unit software.



## 7. Connecting switches/buttons to the control unit

You can use any switch or **button**\* (button only for **Auto Lock** variant) to operate your central locking system. Install the switch/button in the interior of your motorhome in the desired position – in most cases, the area near the living area door is the most suitable.

Please purchase a switch/button from an accessories retailer that is from the same switch series as your motorhome. This switch/button is not included in the scope of delivery from **rv tech**, as it should be individually matched to your switch series.

**TIP:** Remove one of your switches/buttons and look for the manufacturer's label. It is often sufficient to simply remove the attached switch cover.

Use the twin cable supplied by us and connect it to the two silver-colored plugs on the control unit. The polarity on the switch/button and on the control unit is not important: you can connect the black-red cable to the switch and the control unit as you wish.

**TIP:** If you are not satisfied with the assignment of the locking position after connecting the switch/button, simply rotate your switch/button 180 degrees.

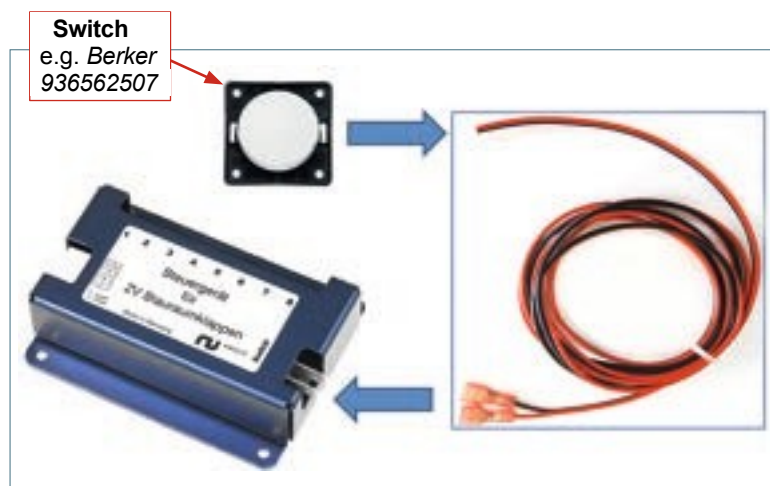

\* **Push button:** Activated by pressing and then returns to its original position.



## 5 WIRING OF THE LOCKS

### 1. Laying the wiring in the vehicle



**Each individual lock is wired to the control unit.** Use the 4-meter cables supplied for this purpose – 4 of these are included in the delivery (can also be reordered).

Both plugs on these cables are coded and therefore cannot be inserted incorrectly into either the lock or the control unit. You can also assign any of the 8 plugs on the connection strip to the control unit as you wish.

*Since the individual cabling depends heavily on your motorhome, we can only provide general information here:*



If your motorhome has a double floor, you should use it to lay the connection cables in flat, self-adhesive **cable ducts**.

T-pieces and 90-degree angles are also available to match the cable ducts.

For example: [www.netproshop.de](http://www.netproshop.de)

*TIP: Alternatively, you can also secure the cables in the raised floor using fabric tape.*



**PMA protective hoses**, such as *Igus I-CYLT-10B*, are suitable for the transitions to the storage compartment flaps.

[www.igus.de](http://www.igus.de)



To secure your cable hoses, please use **cable hose clips** or **cable clamps**, such as the

*Berner cable clamp DIN 72571, galvanized, steel*

[shop.berner.eu](http://shop.berner.eu)



The cable routing at the storage compartment flap is carried out, as shown, under any carpet that may be present or also with flat cable ducts.





## 2. Installation examples

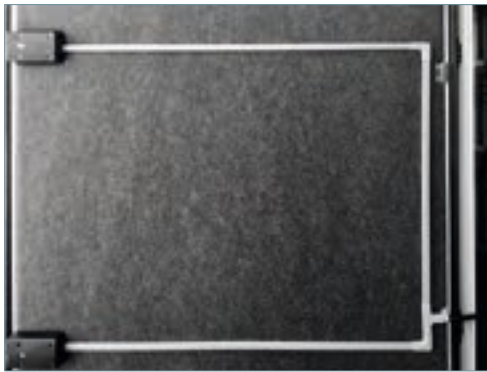

**Installation example Carthago C-Line/C-Tourer:**  
Successful cable routing **on** existing carpet.



**Installation example Carthago C-Line/C-Tourer**  
Successful cable routing **under** the carpet.



**Installation example Carthago C-Line/C-Tourer**  
The two rear garage flaps are connected by cable via the brown cable duct.



**Installation example: Carthago C-Line semi-integrated**  
Cable ducts on the rear flap.



**Installation example: Carthago C-Line semi-integrated**

Even the chemical toilet has been integrated into the system.



**Installation example: Carthago C-Line/C-Tourer**

Plenty of space: The control unit could be easily integrated into the electrical center of the rear garage.





## 6 CHECKING THE STS/HAPPICH LOCKS



Once all the above steps have been completed, reconnect the body battery.

Now check all locks individually using your built-in switch or remote control (in both positions: *open* and *locked*) and then check by hand whether the flap is locked or not.

If, contrary to expectations, an actuator does not work reliably despite correct wiring, loosen the screw on the back of the lock box just a little more (maximum 1/8 turn) to give the mechanical locking parts a little more play.

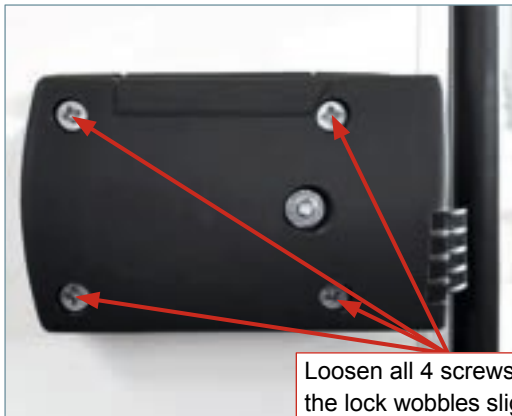

If the locks still cannot be closed or opened, this may be because the pin of the mechanical lock is slightly too long.

You can check this as follows:

Loosen the 4 screws that hold the recessed handle lock in the flap until you can easily turn or move the lock in the cutout of this flap.

Now activate the central locking system: if it now works properly (you will hear this clearly from the sound of the actuators), the pin of the mechanical lock is too long and is obstructing the movement of the actuators.

*Lock manufacturers Happich and STS supply several versions of their locks so that they can be fitted to storage compartment flaps with different wall thicknesses.*

*Especially in the case of flaps that are rather thin due to tolerances or that do not have carpet on the inside, the pin can hinder the rotational movement of the bolt for this reason.*



Shorten the pin by about 1 mm

(The pin is made of aluminum and is therefore easy to file or saw off).

The locks will now function smoothly. Of course, the lock can still be opened mechanically with a key.

If you encounter any problems installing the system, please contact **RV tech** directly: by email or phone



## YOUR NOTES



**RESPONSIBLE FOR CONTENT**

**RV tech** hopes you enjoy your  
new comfort feature and  
relaxing trips with your motorhome!

**RV tech****Technology for motorhomes****Owner** Prof. Dr. Tim NosperRaueneggstraße 29/1  
88212 Ravensburg

Phone

Fax

**Website** [www.rv-tech.de](http://www.rv-tech.de)**Email** [info@rv-tech.de](mailto:info@rv-tech.de)

*As of November 28, 2024  
Version V15*



